

Product Data Sheet



LE-VPP 200R-FI-SG

EAN 4047526387501

ID 387506

Pressed steel swivel castor with top plate fitting and 'stop-fix' brake, Wheel with standard solid rubber tyres, with synthetic rim, non-marking

Bracket:

Made of pressed steel, with double ball bearing in the swivel head, ball protection by the special top plate and ball disc design. The special Blickle dynamic riveting process of the swivel head results in minimal swivel head play and smooth rolling characteristics with an increased service life achieved by the work hardening of the ball race grooves. Bolted wheel axle. Zinc-plated, blue-passivated, Cr6-free.

Wheels:

Made of standard solid rubber, very high operational comfort, low-noise operation, very good floor preservation, PAH conform acc. to EU directive 2005/69/EC.

Tread/tyre: Made of standard solid rubber.

Tread colours grey

Wheel centre/rim:

Made of high-quality, impact-resistant polypropylene. Pressed-on tyre.

Wheel centre colour: black

Variant: non-marking



Rolling resistance

■ ■ □ □ □ Satisfactory

Operating noise

■ ■ ■ ■ □ Very good













Floor surface preservation

■ ■ ■ ■ □ Very good

Product Data Sheet



Technical data

Plate size		140 x 110
Bolt hole spacing		105 x 75-80
Bolt hole Ø		11
Wheel Ø		200 mm (D)
Wheel width		50 mm (T2)
Load capacity		205 kg
Total height		235 mm (H)
Offset swivel castor		54 mm
unit weight		3,2 kg
Temperature resistance		-20 ° C
Temperature resistance to		60 ° C
tread and tyre hardness		80° Shore A
Bearing type:		Roller bearing

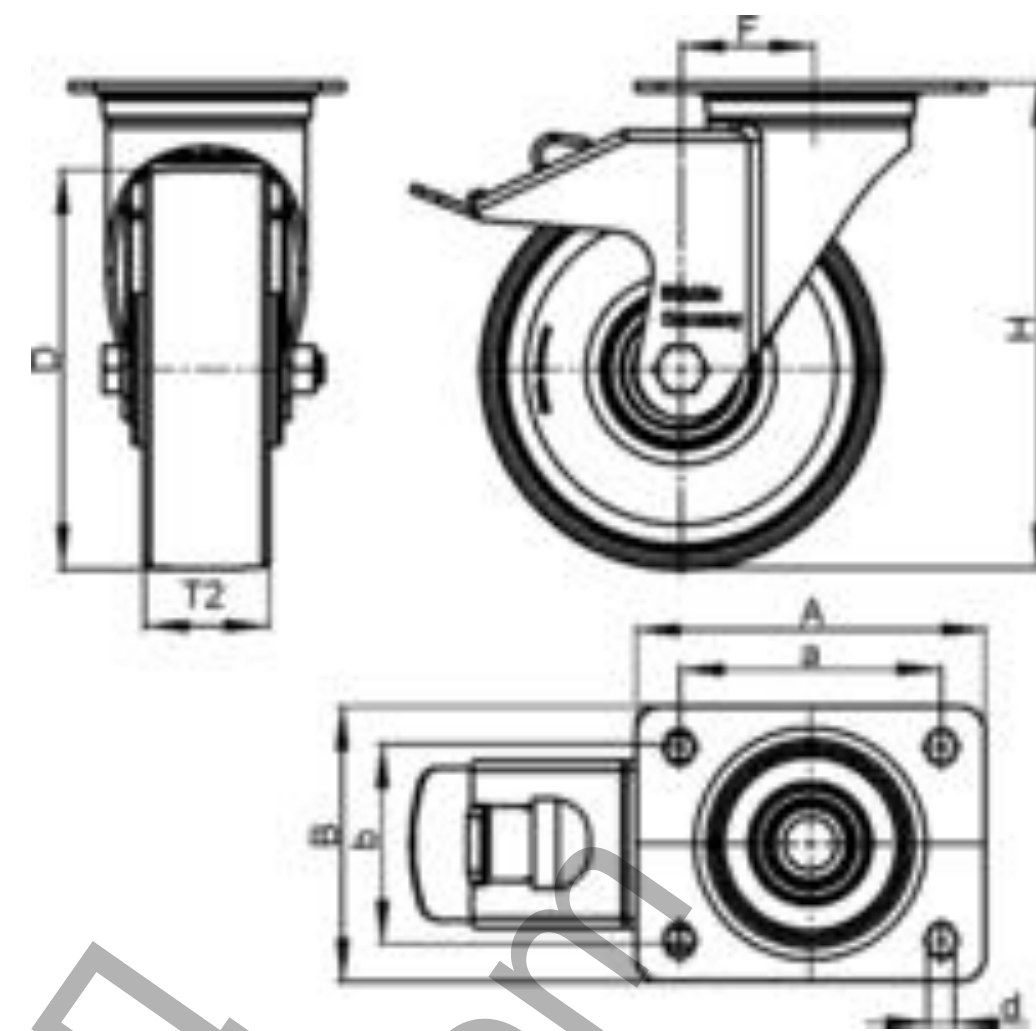

Ташев-Галвинг ООД
www.tashev-galving.com